



FLANGE TOOL INNOVATION

PRODUCT DATA SHEET



HP350D
HP550D
HP1000D

HYDRAULIC TWIN-PORT SEALED HAND-PUMP

MAX PRESSURE RATING:

1st Stage: 13.8 bar (197 psi)

2nd Stage: 700 bar (10 000 psi)

TOOL DESCRIPTION

The Hydraulic Twin-Port Hand-Pump range is tailored for use with Equalizer International hydraulic equipment. Its output is regulated to 700 bar (10 000 psi) and is delivered from a pair of output ports, each threaded 3/8" NPT. The pumps can be used with any 700 bar (10 000 psi) rated hydraulic equipment within their oil capacity specification. The diaphragm oil-reservoir design means that, unlike conventional units, the hand-pumps are operable at all angles and are highly resistant to accidental spillage of hydraulic fluid. For further details please request or download an instruction manual.

	STAGE	HP350D	HP550D	HP1000D
PUMP TYPE		TWO SPEED	TWO SPEED	TWO SPEED
PRESSURE RATING	1st	13.8 bar (197 psi)	13.8 bar (197 psi)	13.8 bar (197 psi)
	2nd	700 bar (10 000 psi)	700 bar (10 000 psi)	700 bar (10 000 psi)
NOMINAL OIL CAPACITY		350 cc (21.4 in ³)	550 cc (33.6 in ³)	1000 cc (61.0 in ³)
USABLE OIL CAPACITY		300 cc (18.3 in ³)	580 cc (35.4 in ³)	1110 cc (67.7 in ³)
OIL VOLUME PER STROKE	1st	3.62 cc (0.221 in ³)	3.62 cc (0.221 in ³)	3.62 cc (0.221 in ³)
	2nd	0.77 cc (0.047 in ³)	0.77 cc (0.047 in ³)	0.77 cc (0.047 in ³)
MAX HANDLE EFFORT		33 kgf (72.75 lbf)	25 kgf (55.12 lbf)	21 kgf (46.30 lbf)
PISTON STROKE		18 mm (0.71")	18 mm (0.71")	18 mm (0.71")



info@equalizerinternational.com
www.equalizerinternational.com

HP350D | HP550D | HP1000D

HYDRAULIC TWIN-PORT SEALED HAND-PUMP



FLANGE TOOL INNOVATION

KIT COMPONENTS

HP350D

- 1 x HP350D Pump Unit
- 2 x 700 bar (10 000 psi) Gauges
- 2 x 3/8" Port Gauge Adaptors
- 1 x Instruction Manual
- 1 x Cardboard Packaging

Packaging Dimensions:
250 mm x 180 mm x 600 mm
(9.84" x 7.09" x 23.62")

Product Code: HP350DMIN

HP550D

- 1 x HP550D Pump Unit
- 2 x 700 bar (10 000 psi) Gauges
- 2 x 3/8" Port Gauge Adaptors
- 1 x Instruction Manual
- 1 x Cardboard Packaging

Packaging Dimensions:
250 mm x 180 mm x 700 mm
(9.84" x 7.09" x 27.56")

Product Code: HP550DMIN

HP1000D

- 1 x HP1000D Pump Unit
- 2 x 700 bar (10 000 psi) Gauges
- 2 x 3/8" Port Gauge Adaptors
- 1 x Instruction Manual
- 1 x Cardboard Packaging

Packaging Dimensions:
250 mm x 180 mm x 900 mm
(9.84" x 7.09" x 35.43")

Product Code: HP1000DMIN

WEIGHTS AND DIMENSIONS

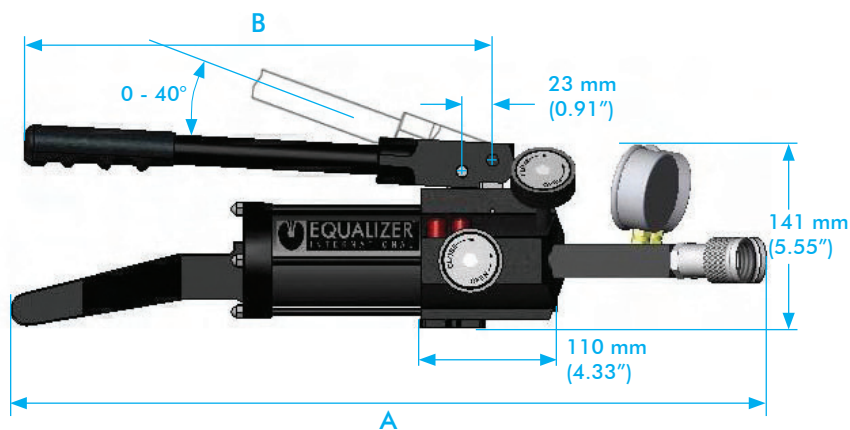
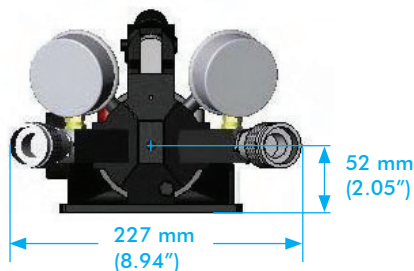

	HP350D	HP550D	HP1000D
OVERALL LENGTH (A)	580 mm (22.83")	669 mm (26.34")	893 mm (35.16")
HANDLE LENGTH (B)	360 mm (14.17")	490 mm (19.29")	537 mm (21.14")
PUMP WEIGHT	4.4 kg (9.7 lb)	5.0 kg (11.0 lb)	6.1 kg (13.4 lb)
GROSS KIT WEIGHT	5.1 kg (11.2 lb)	5.5 kg (12.1 lb)	6.6 kg (14.6 lb)