

THB winch, capacity 4 t

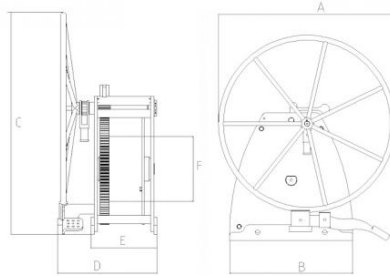

Pulling winch for barges. Capacity of 4 t (10 t for holding).

Use:

- Pulling/hauling operations only
- Anchorage of barges together for river sailing
- Anchorage of barges for mooring at dock

Technical properties

- Very rugged mechanical construction.
- Steel chassis and drum.
- Straight cut gearing, high tensile steel.
- Drum and shafts mounted on self-lubricated bearings.
- Operated by right hand or left hand wheel.
- Retaining ratchet.
- Lever-operated locking ratchet.
- Pedal brake acting directly on hand wheel.

Technical characteristics of THB winch, capacity 4 t

References	THB4000
Capacity 1st layer kg	5100
Capacity top layer kg	4000
Nb of layers	4
Wire rope cap. 1st layer m	7.5
Wire rope cap. top layer m	46
Travel/hand wheel revolution mm	150
Wire rope Ø mm	16
Weight (without wire rope) kg	250

Dimensions

References	THB4000
A mm	950
B mm	660
C mm	1100
D mm	495
E mm	326
F mm	324

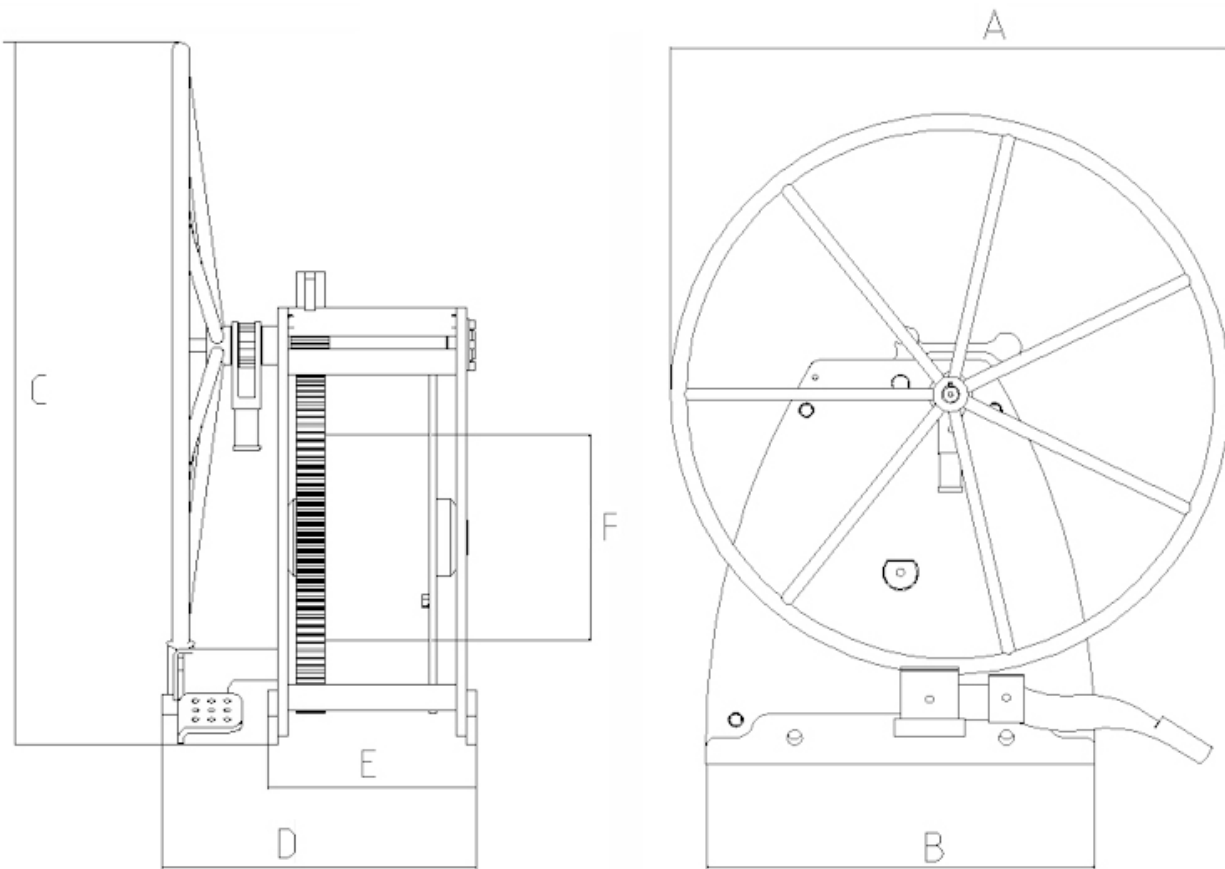

Technical characteristics of the other models of the range

References	THB4000
Capacity 1st layer kg	5100
Capacity top layer kg	4000
Nb of layers	4
Wire rope cap. 1st layer m	7.5
Wire rope cap. top layer m	46
Travel/hand wheel revolution mm	150
Wire rope Ø mm	16
Weight (without wire rope) kg	250



HUCHEZ's advice

Robust due to rugged mechanical construction.



HUCHEZ
9, Grande Rue
60420 FERRIERES – France
☎ +33 (0) 3 44 51 11 33
Site internet : www.huchez.com
E-mail : contact@huchez.fr



SERVICE
CLIENTS

Pour en savoir plus, n'hésitez pas à nous contacter !
To know more, please contact us!

